

SC/T-SC 輕便不阻塞型規格表

| Inlet | Model Number | | Motor | | Power Line |
|------------|--------------|-------------------|-------|-------|------------|
| | Standalone | Guide Rail System | KW | HP | M |
| 2" | SC-4-50 | T-SC-4-50 | 0.4 | 1/2 | 5 |
| | SC-7-50 | T-SC-7-50 | 0.75 | 1 | 5 |
| | SC-15-50 | T-SC-15-50 | 1.5 | 2 | 5 |
| 3" | SC-15-80 | T-SC-15-80 | 1.5 | 2 | 5 |
| | SC-22-80 | T-SC-22-80 | 2.2 | 3 | 5 |
| 3" (4") | SC-37-80/100 | T-SC-37-80/100 | 3.7 | 5 | 5 |
| | SC-55-80/100 | T-SC-55-80/100 | 5.5 | 7 1/2 | 5 |

性能選擇表(PERFORMANCE CURVES)

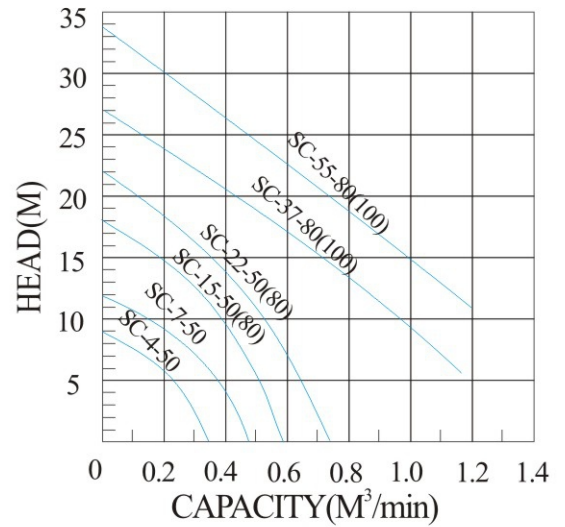

外型尺寸圖(Dimensions)

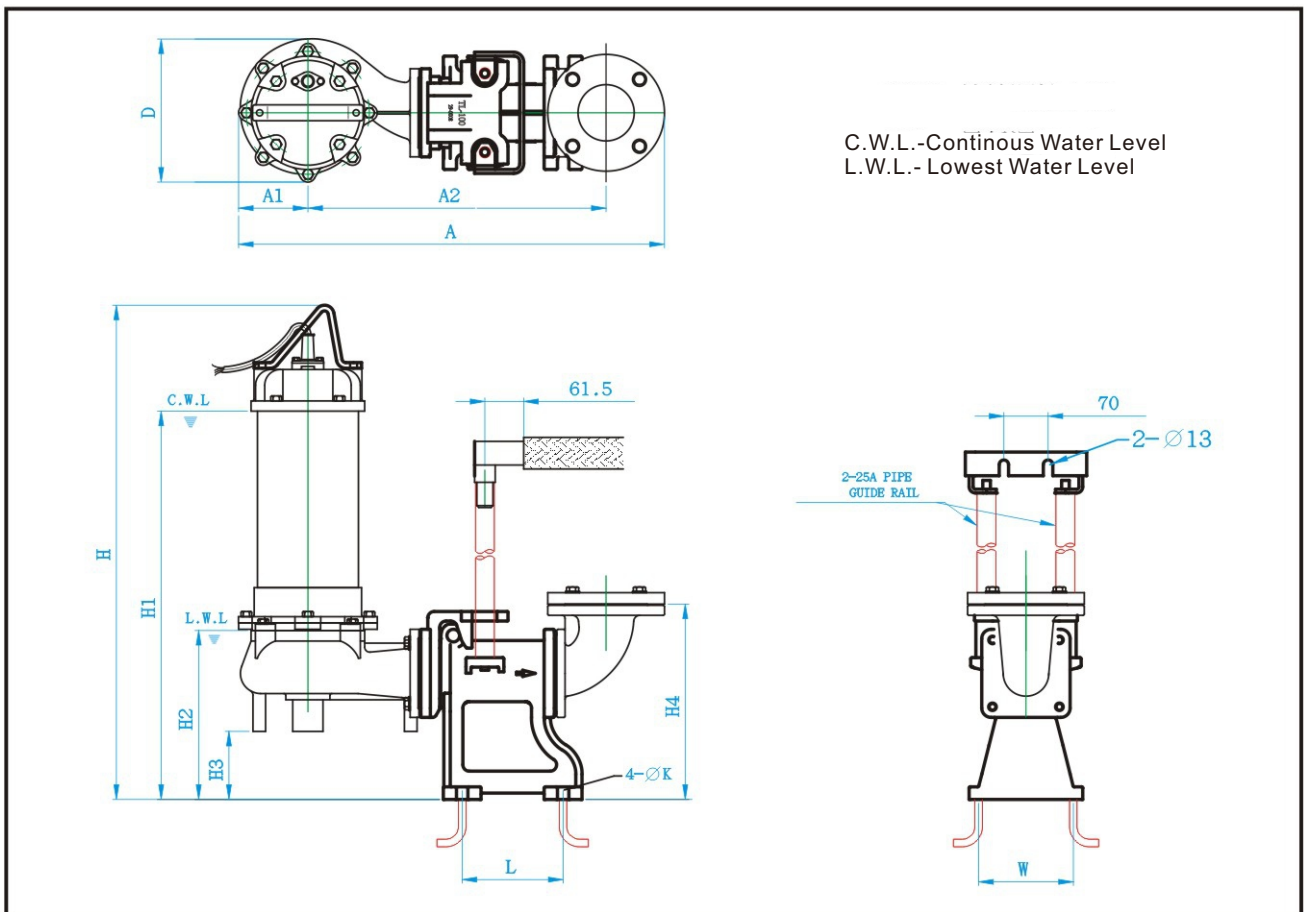

| MODEL | Motor | | Dimensions (mm) | | | | | | | | | | | |
|----------------|-------|-----|-----------------|-----|-----|-----|-----|-----|-----|-----|-----|-----|-----|----|
| | KW | HP | A | A1 | A2 | D | H | H1 | H2 | H3 | H4 | L | W | K |
| T-SC-4-50 | 0.4 | 1/2 | 477 | 81 | 303 | 163 | 499 | 384 | 196 | 76 | 241 | X | 140 | 14 |
| T-SC-7-50 | 0.75 | 1 | 477 | 81 | 303 | 163 | 548 | 423 | 196 | 76 | 241 | X | 140 | 14 |
| T-SC-15-50/80 | 1.5 | 2 | 550 | 105 | 350 | 210 | 640 | 475 | 210 | 80 | 241 | X | 140 | 14 |
| T-SC-22-50/80 | 2.2 | 3 | 550 | 105 | 350 | 210 | 660 | 495 | 210 | 80 | 241 | X | 140 | 14 |
| T-SC-37-80/100 | 3.7 | 5 | 675 | 110 | 473 | 230 | 745 | 580 | 270 | 110 | 310 | 160 | 150 | 14 |
| T-SC-55-80/100 | 5.5 | 7.5 | 675 | 110 | 473 | 230 | 785 | 620 | 270 | 110 | 310 | 160 | 150 | 14 |